

The product models and specifications published in this manual are for reference only, and everything is subject to the actual product and product description.

|   |   |
|---|---|
| <b>PRODUCT<br/>QUALIFICATION<br/>CERTIFICATE</b>  |   |
| <b>Name:</b>  | Reactive Power<br>Compensation Controller |
| <b>Model:</b>   | JKW-PV                                    |
| This product meets the standard for<br>crystal inspection and is allowed to<br>leave the factory. |   |
| <b>Inspector:</b>   | Test 9                                    |

---

Due to product upgrades and version updates, the content described in this manual is subject to the actual product. If there are any errors, omissions, or other inappropriate aspects, we kindly ask for your understanding.

**Copyright Notice:**

The copyright of this manual belongs to our company. Anyone who copies this manual without our written consent will bear legal responsibility.

# OPERATION INSTRUCTIONS

---



## JKW-PV Series

Reactive Power Automatic  
Compensation Controller  
(Four Quadrants of Photovoltaic System)

Note: The working mode of this controller has been adjusted to power factor control mode before leaving the factory, and all parameters have been pre-set in the most reasonable way. Unless there are special requirements, users can work normally as long as the wiring is correct without any operation.

## 1. Product Overview

JKW-PV photovoltaic system four quadrant reactive power compensation controller, suitable for automatic adjustment of capacitor compensation devices in low-voltage distribution systems (hereinafter referred to as the controller), enables the power factor to reach the user's predetermined state, improves the utilization efficiency of power transformers, reduces line losses, and improves the voltage value of power supply, thereby improving economic and social benefits.

## 2. Four Quadrant Configuration of Photovoltaic System

Press and hold the up and down keys, display 1234 for four quadrants, display 14 for two quadrant operation without photovoltaic lower controller.

## 3. Conditions of Use

1. The altitude shall not exceed 2500 meters.
2. The ambient temperature is -25°C+50°C.
3. The air humidity should not exceed 50% at 40°C and 90% at 20°C.
4. The surrounding environment is free of corrosive gases, conductive dust, and flammable and explosive media.
5. There is no severe vibration at the installation location.

## 4. Technical Parameter

|                                      |   |
|--------------------------------------|---|
| <b>Rated operational voltage</b>     | 380V 50Hz                               |
| <b>Rated working current</b>         | AC 0~5A 50Hz                            |
| <b>Output contact capacity</b>       | AC 220V 7A 50Hz                         |
| <b>Display power factor</b>          | Lag 0.001~Lead 0.001                    |
| <b>Measure reactive power</b>        | 0~9999 Kvar                             |
| <b>Undervoltage protection value</b> | 300V                                    |
| <b>Control mode</b>                  | Automatic optimization/cyclic switching |
| <b>Sensitivity</b>                   | 60mA                                    |
| <b>Protection grade</b>              | Shell IP40                              |

## 5. Characteristics of Working Mode:

The controller can only work in one working mode at any time.

**The characteristics of power factor control mode:** This controller has been adjusted to power factor control mode before leaving the factory, and all parameters have been pre-set in the most reasonable way. Users can work normally as long as the wiring is correct without any operation.

**The characteristics of reactive power control mode:** It can accurately control the switching of capacitor banks without switching oscillation, suitable for all working environments, especially for fields with light loads and large capacitance.

## 6. Selection of Power Factor Control Mode and Reactive Power Control Mode

The selection of the controller's working mode is distinguished by the different values of the *PR-4* parameter. If the user adjusts this parameter within (1-16), it indicates that in the controller's working power factor mode, the size of the data represents the number of output loops of the controller; If the user adjusts the parameters within (50~5000), it indicates that the controller is operating in reactive power control mode, and the size of the data represents the total current transformer ratio of the user's system.

**Note: In reactive power control mode, users must input the actual current transformer ratio and all capacitor capacities and other parameters to the controller before using it.**

## 7. Display Content of Each Menu Under Different Working Modes

| Working mode                | COS                               | Q(kvar)                              | Manual operation     |
|-----------------------------|-----------------------------------|--------------------------------------|----------------------|
| Reactive power control mode | Automatic display of power factor | Automatically display reactive power | Display power factor |
| Power factor control mode   | Automatic display of power factor | Display reactive power               | Display power factor |

## 8. Debugging

**Warning: Users must follow the following debugging steps during the debugging process, where the operation items marked with a ☆ indicate that the controller is working in reactive power control mode.**



1. Assemble the compensation device according to the requirements of the wiring diagram and conduct a detailed inspection to eliminate errors that may cause serious safety hazards.
2. The compensation device is closed and the controller enters automatic operation mode.
- ☆ 3. Enter the transformation ratio of the on-site signal current transformer, see menu operation for details.
- ☆ 4. Enter the capacity of each branch capacitor bank, see menu operation for details.
5. Press the "Menu" button to turn on the manual operation indicator light. Manual operation, as a means of debugging the compensation device, can be used to check whether its wiring is correct. Press the increase button to activate a capacitor bank and press the decrease button to disconnect a capacitor bank.

**Attention: The output terminal with a corresponding capacitor value of zero cannot be switched.**

**The above operation may not have a current signal.**

6. In order for the controller to automatically switch capacitor banks, in addition to the user placing the menu under the "Power Factor" or "Reactive Power" menu, there must also be a current signal that lags behind the voltage signal, and the system voltage must not be higher than the overvoltage protection value or lower than the undervoltage protection value.

**9. Key Function**

| Name                   | Symbol  | Content   |
|------------------------|---|---|
| <b>Menu key</b>        |  | Main menu, submenu selection.<br>Note: Press and hold the menu button for 3 seconds to enter the parameter preset menu.   |
| <b>Incremental key</b> |  | Add data when presetting parameters, and activate the capacitor bank when manually running.   |
| <b>Decreasing key</b>  |  | Reduce data when presetting parameters, and disconnect the capacitor bank during manual operation<br>Under the "Power Factor" menu: The power factor control mode displays the secondary current in mA<br>Reactive power control mode displays primary current A<br>Under the "Reactive Power" menu: Display voltage signal value V |

**10. Menu Operation**

1. Parameter adjustment steps in power factor control mode

| Selection of pre-set parameters   | Parameter code  | Code meaning         | Parameter range       | Reference parameters                 |
|---|---|----------------------|-----------------------|--------------------------------------|
| Press and hold the "Menu" button for 3s to turn on the "Parameter Preset" indicator light | <i>PR-1</i>   | Investment threshold | Lag 0.70~Lead 0.70    | Lag 0.95                             |
| Press the "Menu" button again   | <i>PR-2</i>   | Delay preset         | 1~250s                | 30s                                  |
| Press the "Menu" button again   | <i>PR-3</i>   | Overvoltage preset   | 230~260V(or 380~500V) | 240(430V)                            |
| Press the "Menu" button again   | <i>PR-4</i>   | Circuit preset       | 1~16 Route            | 4-16 routes are related to the model |
| Press the "Menu" button again   | <i>PR-5</i>   | Cut off threshold    | 0.70ind~0.70cap Note③ | 1.0                                  |
| Press the "Menu" button again for 3s  | Store pre-set parameters and enter automatic operation mode |                      |                       |                                      |

2. Parameter adjustment steps in reactive power control mode

| Selection of pre-set parameters   | Parameter code  | Code meaning                    | Parameter range        | Reference parameters |
|---|---|---------------------------------|------------------------|----------------------|
| Press and hold the "Menu" button for 3s to turn on the "Parameter Preset" indicator light | <i>PR-1</i>   | Target power factor             | Lag 0.70 ~ Lead 0.70   | Lag 0.98             |
| Press the "Menu" button again   | <i>PR-2</i>   | Delay preset                    | 1~250s                 | 30s                  |
| Press the "Menu" button again   | <i>PR-3</i>   | Overvoltage preset              | 230~260V (or 380~500V) | 240(430V)            |
| Press the "Menu" button again   | <i>PR-4</i>   | CT ratio preset                 | 50~5000 Note ①         | Actual configuration |
| Press the "Menu" button again   | <i>C-01</i>   | 1th circuit capacitor capacity  | 0~150.0Kvai Note ②     | Actual configuration |
| Press the "Menu" button again   | <i>C-02</i>   | 2th circuit capacitor capacity  | 0~150.0Kvai Note ②     | Actual configuration |
| Press the "Menu" button again   | ... ..  | ... ..                          | ... ..                 | Actual configuration |
| ... ..  | <i>C-16</i>   | 16th circuit capacitor capacity | 0~150.0Kvai Note ②     | Actual configuration |
| Press the "Menu" button again for 3s  | Store pre-set parameters and enter automatic operation mode |                                 |                        |                      |

**The following annotations must be carefully read by users**

- Note: ① In reactive power control mode, the CT ratio preset value is the molecular value of the signal current transformer ratio. If the user's signal current transformer ratio is 500/5A, then the CT ratio preset value is 500 instead of 100.
- ② In the low-power control mode, the capacity parameter of the output circuit without a capacitor bank should be pre-set to "0"; The output circuit controller does not output control signals for capacitors with a preset capacity of "0".
- ③ In power factor control mode, the cut-off threshold parameter must be higher than the input threshold parameter by 0.02 or more. If the user mistakenly modifies the cutoff threshold parameter to a value lower than the input threshold value+0.02, the parameter modification program will automatically set the cutoff threshold parameter to the current input threshold parameter+0.05 value.

**11. Display Description**

|                      |   |
|----------------------|---|
| Overpressure filling | ☆ If the current menu indicator light flashes, it indicates that the controller is working in the overvoltage cut-off state, and the displayed value is the system voltage value. |
| COS value            | ☆ Displaying <i>0.985</i> indicates that the current power factor is lagging by 0.985, while displaying <i>-985</i> indicates that the current power factor is leading by 0.985.  |
| Undercurrent state   | ☆ Display <i>C--0</i> indicates undercurrent, signal current is less than 60mA.   |

**12. Wiring Diagram**

JKW-PV-12S wiring diagram (sampling voltage 380V)  
Hole size: 113×113mm (Figure 1)

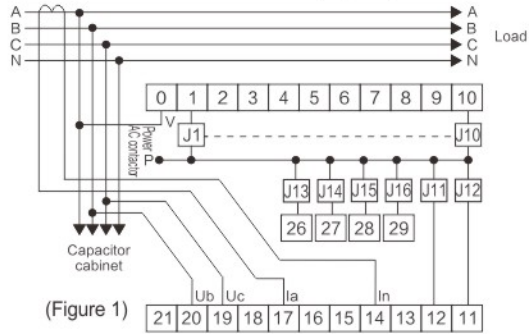

- The only difference between Figure 1 and Figure 2 is the sampling voltage, everything else is completely consistent.
- 1) Figure 1 shows line voltage sampling, with voltage signals connected to Ub and Uc;  
Figure 2 shows phase voltage sampling, with voltage signals connected to Ua and Un.
  - 2) Ia, In sampling current signal input.
  - 3) Terminals 1-12 and 26-29 are 16 channel control open point signal outputs, connected to J1-J16 contactor coils.
  - 4) The common input terminal of the V control output terminal and the voltage connected to the common terminal P of the external contactor coil must meet the voltage requirements of the contactor coil.

JKW-PV-12S wiring diagram (sampling voltage 380V)  
Hole size: 113×113mm (Figure 3)

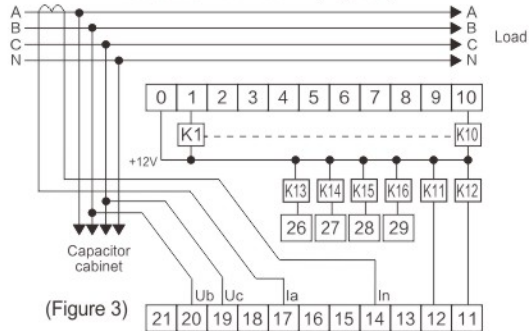

- The only difference between Figure 3 and Figure 4 is the sampling voltage, everything else is completely consistent.
- 1) Figure 3 shows line voltage sampling, with voltage signals connected to Ub and Uc;  
Figure 4 shows phase voltage sampling, with voltage signals connected to Ua and Un.
  - 2) Ia, In sampling current signal input.
  - 3) Terminals 1-12 and 26-29 are negative outputs of 16 DC control signal signals, connected to the control negative terminals of K1-K16 capacitor switches.
  - 4) The common output of the V control output is 12V, and the V terminal needs to be connected in parallel with the control positive terminal of the K1-K16 capacitor switch.

**13. Malfunctions and troubleshooting**

During the installation and use of the controller, some easily overlooked wiring errors may cause the compensation device to operate abnormally. The following are several common fault phenomena and their solutions:

- 1. The operation indicator on the control head panel is on, but the AC contactor is not engaged.** This phenomenon is caused by the coil of the AC contactor not receiving power or the power supply being too low. Users should check whether the model of the AC contactor is consistent with the drawing, whether the fuse is intact, whether the common terminal of the AC contactor power supply and the common terminal of the controller output are connected to the same wire, and whether there is an open circuit in the wiring.
- 2. With the input of capacitors, the power factor changes abnormally or not much.** The former phenomenon is caused by incorrect sampling of voltage or current signals, and users should focus on checking the sampling of signals. The latter is caused by the incorrect positioning of the user's signal current transformer, which should be placed in a location where its output can reflect changes in the total load current (such as the main cabinet busbar).
- 3. The controller header always displays  $\infty$ -0.** This phenomenon is caused by the signal current input to the controller being too small (less than 60mA) or no current. Users should calculate whether the selection of the current transformer ratio is reasonable. Is there an open circuit or series parallel connection of other instruments in the current signal circuit.
- 4. One or several sets of capacitors are never put into operation (the operation indicator light is also not on).** This phenomenon only occurs in reactive power control mode, usually because the user did not pre-set the capacitor capacity or the pre-set data is too large when modifying parameters. They only need to reset the capacitor capacity.
- 5. The difference between the reactive power value displayed by the controller and the actual value is too large.** This phenomenon is generally caused by incorrect preset transformation ratio of the current transformer. Users should check whether the transformation ratio of the signal current transformer is consistent with the preset value.
- 6. The power factor value displayed by the controller is significantly different from the actual value.** There are two possibilities for this phenomenon:
  - a. Is there an error in the sampling of voltage or current signals.
  - b. The current signal exceeds 5.5A (unreasonable selection of current transformer ratio).
- 7. If users encounter problems that they cannot solve, they should contact their local distributors or manufacturers for technical consultation.**

- Note:**
- ① Our company can also customize controllers with special specifications for users, such as controllers with switching oscillation locking function, controllers with special parameters such as line voltage 220V, 110V, 60Hz, etc.
  - ② Our company's products have quality problems within three months from the date of delivery, and we guarantee replacement with a new machine. If any quality problems occur within eighteen months, we will provide free repairs for users (excluding damage caused by human factors or other products).